



GALAXY FIXATION™ SYSTEM LOWER EXTREMITIES

INTRODUCTION AND INDICATIONS	1
INDICATIONS IN TRAUMA	1
FEATURES AND BENEFITS	2
CLAMP CLOSURE PROCEDURES	5
GALAXY FIXATION™ TL-HEX CONNECTION SYSTEM	8
EQUIPMENT REQUIRED	9
GENERAL INSTRUCTIONS	12
MULTI-SCREW CLAMPS	16
APPLICATION BY ANATOMICAL SITE	17
DAMAGE CONTROL	24
KEY PRINCIPLES FOR STABILITY IN EXTERNAL FIXATION	26
MRI INFORMATION	28

Operative Technique Contributing Surgeon:

S. Nayagam, MD
Pr. A. C. Masquelet, MD

INTRODUCTION AND INDICATIONS

External fixators have become multi-function devices with indications for use in trauma and Orthopaedics. It is used for damage control or definitive treatment of injuries whereas Orthopaedic applications have included reconstructive surgery. The Galaxy Fixation™ system is designed to provide the multi-function capabilities of an external fixator for modern trauma and reconstructive surgery. The components have been designed for rapid application, stability and ease of use. The modules of the Galaxy Fixation™ system have a consistency of design across the range of trauma and reconstructive modules. This ensures that surgeons can become accustomed to the entire range quickly. Additionally, the system encompasses the facility for use in small and large long bones and thus extends to cover adult and paediatric applications. This wide capability has been designed with stability being a primary system characteristic.

In so doing, the surgeon can:

- place screws where the condition of the bone and soft tissues permits
- reduce the fracture or joint in order to restore alignment easily
- achieve stability with the efficient use of bone screws, rods and clamps (examples of fixator configurations which provide stability through optimal use components are provided and thereby contribute to standardisation of use)

The indications for use include:

- Open or closed diaphyseal fractures of the long bones
- Joint pathologies/injuries of upper and lower limbs such as:
 - proximal humeral fractures;
 - intra-articular knee, ankle and wrist fractures;
 - Delayed treatment of dislocated and stiff elbows;
 - Chronic, persistent elbow joint instability;
 - Acute elbow joint instability after complex ligament injuries;
 - Unstable elbow fractures;
 - Additional elbow stabilization of post-operative unstable internal fixation.
- Infected and aseptic nonunions as part of staged treatment
- Vertically stable pelvic fractures or as a treatment adjunct for vertically unstable pelvic fractures

For MRI Information see page 28.

The rods and bone screws are strictly single patient use.

INDICATIONS IN TRAUMA

The use of an external fixator for damage control is to provide skeletal stability and for this to be achieved efficiently; that is, the objective is accomplished quickly and does not hinder future definitive care. Skeletal stability in damage control places considerable strains on an external fixator system as reduction of the fracture is usually approximate and, as such, bone contact at the fracture site and shared stability with the external fixator may be minimal, thereby leaving the provision of stability entirely to the external fixator construct. The Galaxy Fixation™ system has been designed with this characteristic in mind.

External fixators may also be needed for definitive treatment of long bone fractures. The external fixator configuration will depend on the amount of bone contact at the fracture site, the fracture pattern and the segment or segments of bone involved.

This manual provides examples of how fixator configuration can be augmented in some common fracture patterns to create stability sufficient to allow rehabilitation of the patient.



FEATURES AND BENEFITS

Rods

Strong radiolucent rods in three different diameters (12mm for Lower Limb, 9 and 6mm for Upper Limb) and various lengths.



Code	Description
932100	Rod 100mm long
932150	Rod 150mm long
932200	Rod 200mm long
932250	Rod 250mm long
932300	Rod 300mm long
932350	Rod 350mm long
932400	Rod 400mm long
99-932450	Rod 450mm long, sterile*
99-932500	Rod 500mm long, sterile*
99-932550	Rod 550mm long, sterile*
99-932600	Rod 600mm long, sterile*
99-932650	Rod 650mm long, sterile*

* Special order only



Code	Description
939100	Rod 100mm long
939150	Rod 150mm long
939200	Rod 200mm long
939250	Rod 250mm long
939300	Rod 300mm long



Code	Description
936060	Rod 60mm long
936080	Rod 80mm long
936100	Rod 100mm long
936120	Rod 120mm long
936140	Rod 140mm long
936150	Rod 150mm long
936160	Rod 160mm long
936180	Rod 180mm long
936200	Rod 200mm long



Code	Description
936010	6mm L Rod

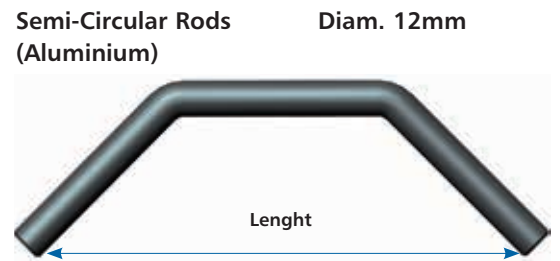

Code	Description
932010	Semi-Circular Rod small 180mm long
932020	Semi-Circular Rod medium 215mm long
932030	Semi-Circular Rod large 250mm long

Semi-Circular Rods **Diam. 9mm**

939010	Semi-Circular Rod small 115mm long
939020	Semi-Circular Rod medium 140mm long
939030	Semi-circular Rod large 165mm long

All rods are also available single-packed and sterile. They can be ordered using the above code numbers preceded by 99- (e.g. 99-932100)

Screws

XCaliber Bone Screws Shaft Ø 6mm- Thread Ø 6.0-5.6mm

Code	Total L	Thread L	Code	Total L	Thread L
912630	260	30	911530	150	30
912640	260	40	911540	150	40
912650	260	50	911550	150	50
912660	260	60	911560	150	60
912670	260	70	911570	150	70
912680	260	80	911580	150	80
912690	260	90	911590	150	90

- Drill bit Ø 4.8mm when the bone is hard
- Drill bit Ø 3.2mm in poor quality bone or in the metaphyseal region

Bone Screws Shaft Ø 6mm - Thread Ø 4.5-3.5mm

Code	Total L	Thread L	Code	Total L	Thread L
10190	70	20	10105	100	40
10191	80	20	10137	120	20
10108	80	30	10138	120	30
10135	100	20	10106	120	40
10136	100	30			

- Drill bit Ø 3.2mm

Bone Screws Shaft Ø 4mm - Thread Ø 3.3-3.0mm

Code	Total L	Thread L	Code	Total L	Thread L
35100	70	20	35101	80	35

- Drill bit Ø 2.7mm

Self-drilling Bone Screws Shaft Ø 4mm - Thread Ø 3.3-3.0mm

Code	Total L	Thread L	Code	Total L	Thread L
37100	60	20	37101	70	30
37102	100	30			

Self-drilling Bone Screws Shaft Ø 3mm - Thread Ø 3.0-2.5mm

Code	Total L	Thread L	Code	Total L	Thread L
M310	50	18	M314	70	20
M311	60	20	M315	70	25
M312	60	25	M316	70	30
M313	60	30	M317	100	30
M321	70	15			

XCaliber Cylindrical Bone Screws

Shaft Ø 4mm - Thread Ø 3.0mm



Code	Total L	Thread L	Code	Total L	Thread L
948320	120	20	947320	100	20
948325	120	25	947325	100	25
948335	120	35			

- Self-drilling

Galaxy Fixation™ System is compatible with all Orthofix Bone Screws with shaft and thread diameters as indicated above. Please refer to the Orthofix Products Catalogue.

Clamps for Independent Screw Placement

Allow easy and stable connection of either a rod and a bone screw or two rods

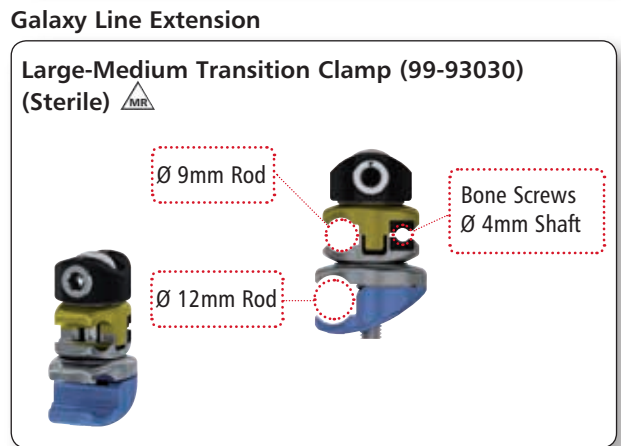
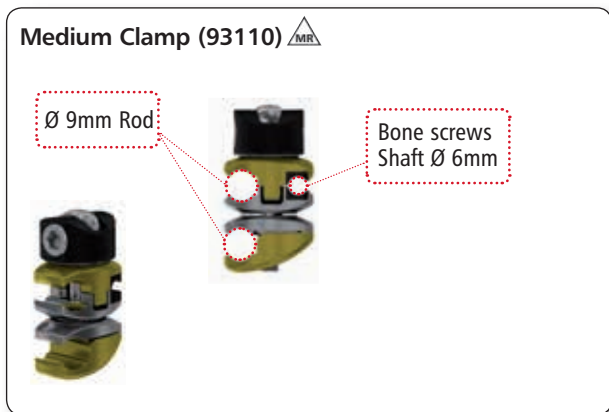
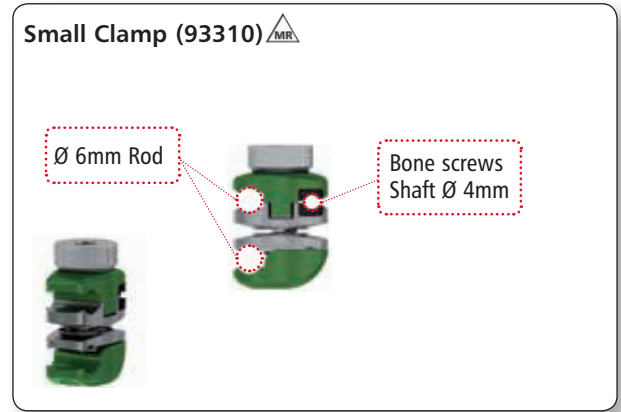
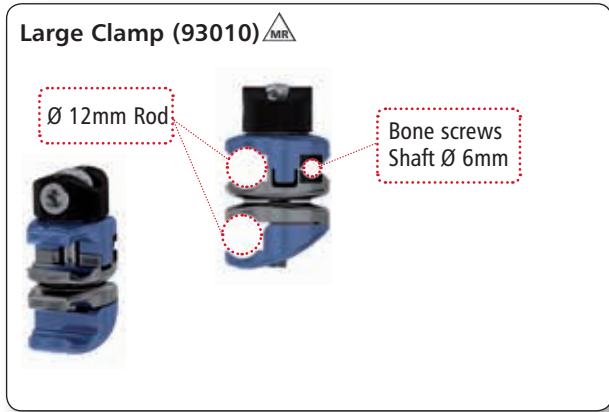

Simple: one clamp for rod-to-rod and pin-to-rod connections

Easy: snap-in system, provisional tightening by hand, definitive cam closure in one step

Versatile: sterile kits for each anatomical site, sterile single-packed components, instrument and implant trays

Stable: internal teeth and locking profiles designed to provide high torsional strength and avoid components sliding
MRI conditional at 1.5 and 3 Tesla

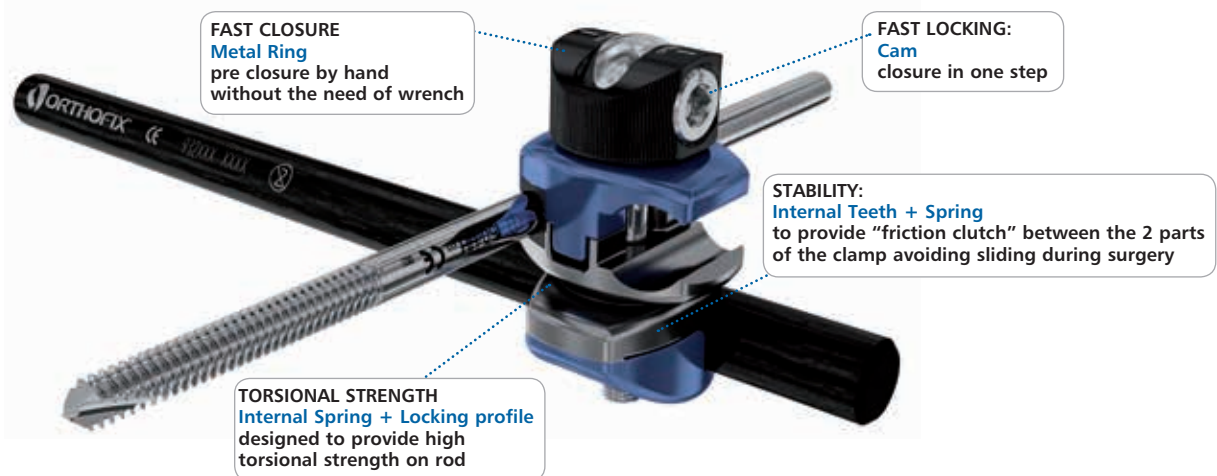

CLAMP CLOSURE PROCEDURES



1 FRAME ASSEMBLY



Start position - Clamp open

The dot on the bolt must be in line with the "OPEN" marking on the metal ring (12 o'clock)



The two halves of the clamp are separated, rods and bone screws can be easily inserted with snap-in system

2 PRELIMINARY CLOSURE AND FRACTURE REDUCTION



Pre-closure by hand

The dot on bolt must be kept in line with the "OPEN" marking on the metal ring (12 o'clock), while by hand the knurled knob is turned clockwise



The two halves of the clamp are now tightened closed, rods and bone screws cannot be inserted anymore

3B

3 DEFINITIVE FRAME LOCKING

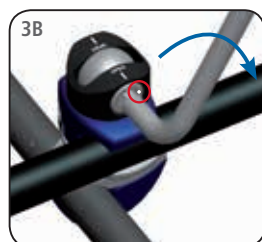
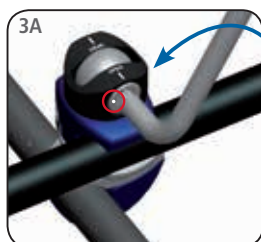

Final closure

The 5mm Allen wrench is inserted in the bolt and is turned either clockwise (3 o'clock- 3B) or counter clockwise (9 o'clock - 3A). This engages a cam for final tightening



Now the dot on cam has moved accordingly

1 FRAME ASSEMBLY



Pre-Closure
Turn the locking screw fully by hand



The two halves of the clamp are separated, rods and bone screws can be easily inserted with snap-in system

2 FINAL CLOSURE

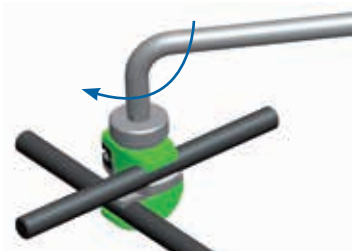

Tighten the locking screw with Wrench



The two halves of the clamp are now tightened closed, rods and bone screws cannot be inserted anymore

STABILITY:
Internal Spring + Locking profile designed to provide high torsional strength on rod

FAST LOCKING:
Cam closure in one step

FLEXIBILITY OF USE:
Rotation up to +/- 35°

FAST INSERTION:
Snap Lock

FAST CLOSURE:
Metal Ring - pre closure by hand without the need of wrench



Multi-Screw Clamp (93020)

- To be used with 12mm Rod and 6mm shaft bone screws.
- Allows parallel screw positioning either in a T- or a straight clamp configuration.

Note: the positions of the screw holes in the multi-screw clamp refer to the screw seats of the XCaliber fixator or the 1,3,5 screw seats of the LRS fixator T- or straight clamps.

Galaxy Line Extension

Medium Multi-Screw Clamp (99-93120) (Sterile)

Allows parallel screw positioning (+/- 35°) in either a T-clamp or straight clamp configuration

Note: the positions of the screw holes in the medium screw clamp refer to the screw seats of the Small Blue D.A.F. (31000) or the pediatric LRS system (series 55000)





Double Multi-screw Clamps

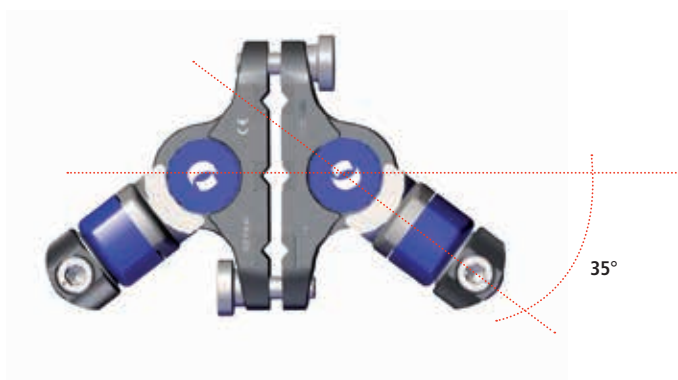
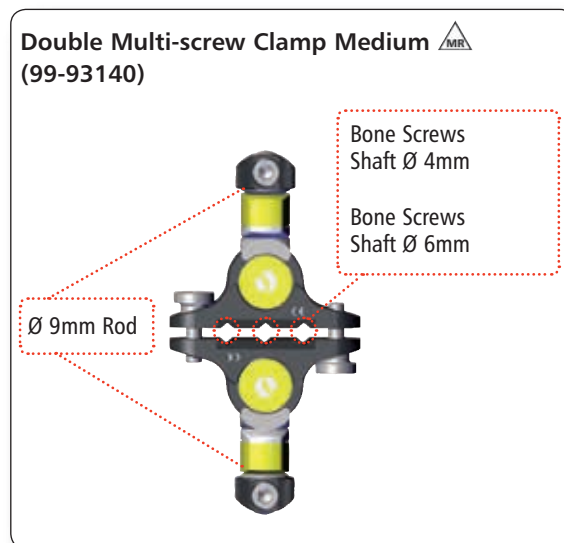
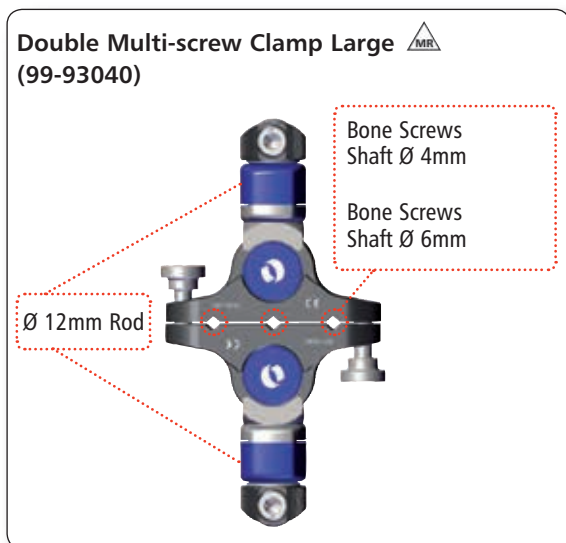

All clamps are also available single-packed and sterile. They can be ordered using the above code numbers preceded by 99- (e.g. 99-93010)

GALAXY FIXATION™ / TL-HEX CONNECTION SYSTEM

TIBIA



PAEDIATRICS APPLICATIONS



Galaxy TL-HEX Connecting Post

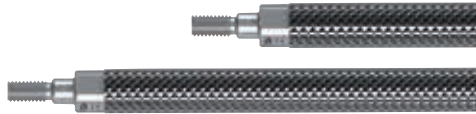

Code	Description
93031	Galaxy TL-HEX Connecting Post L50mm D12mm
93032	Galaxy TL-HEX Connecting Post L100mm D12mm

EQUIPMENT REQUIRED

INSTRUMENTS Galaxy Fixation™ SYSTEM TRAY

Can accommodate:

Code	Description
19940	Multi-screw Clamp Guide
11138	Drill Guide d 4.8mm
11137	Screw Guide 80mm
1-1100201	Drill Bit d 4.8x240mm Coated - Quick Connect
11106	Drill Guide d 3.2mm
11102	Screw Guide 60mm
1-1300301	Drill Bit d 3.2x140mm Coated - Quick Connect
19955	Trocar
19960	Wrist Guide Template with Handle
13530	Drill Guide d 2.7mm
1-1355001	Drill Bit d 2.7x127mm Coated - Quick Connect
19965	Tapered Trocar
M210	T Wrench
93150	Racheting T Handle
93155	Screw Shaft Connection
30017	Allen Wrench 5mm
93017	Wrench 5mm Shaft Connection

RODS & CLAMPS TRAY*

Can accommodate:

Code	Description
Lower Tray	
93010	Large Clamp
93020	Multi-screw Clamp
932400	Rod d 12mm L 400mm
932350	Rod d 12mm L 350mm
932300	Rod d 12mm L 300mm
932250	Rod d 12mm L 250mm
932200	Rod d 12mm L 200mm
932150	Rod d 12mm L 150mm
932100	Rod d 12mm L 100mm
932030	Semi Circular Rod d 12mm large
932020	Semi Circular Rod d 12mm medium
932010	Semi Circular Rod d 12mm small
Upper Tray	
93110	Medium Clamp
93310	Small Clamp
939300	Rod d 9mm L 300mm
939250	Rod d 9mm L 250mm
939200	Rod d 9mm L 200mm
939150	Rod d 9mm L 150mm
939100	Rod d 9mm L 100mm
936200	Rod d 6mm L 200mm
936180	Rod d 6mm L 180mm
936160	Rod d 6mm L 160mm
936140	Rod d 6mm L 140mm
936120	Rod d 6mm L 120mm
936100	Rod d 6mm L 100mm
936080	Rod d 6mm L 80mm
936060	Rod d 6mm L 60mm

TRAY CONFIGURATION

Code	Description
93991C	Galaxy Upper + Lower Complete
93992C	Galaxy Instruments Complete
93993C	Galaxy Lower + Instruments Complete
93996C	Galaxy Lower Complete

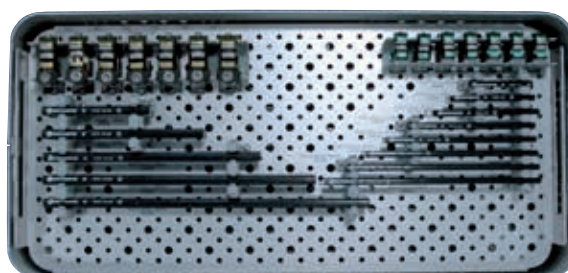
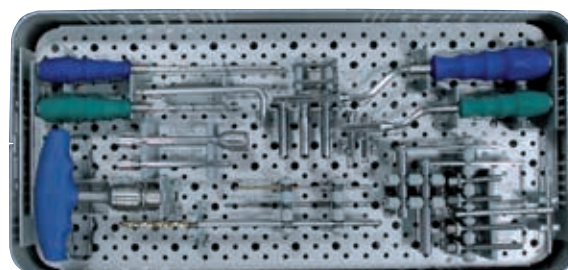

* to order any of the Rods or Clamps, single-packed and sterile, please add 99- prior to the part number, ex. 99-93010

Sterile Kit

Besides the sterile pre-packaged kits, Galaxy Fixation™ System offers all **clamps and rods pre-packaged and sterile individually**. They can be ordered using the code number preceded by 99- (e.g. 99-939300).

99-93501 Pelvis Sterile Kit

Consisting of:

Code	Description
8x93010	Large Clamp
1x932350	Rod d 12mm L 350mm
1x932300	Rod d 12mm L 300mm
2x932200	Rod d 12mm L 200mm
4x912640	Self-drilling XCaliber Screws, L 260mm, thread length 40mm
1x11138	Drill Guide d 4.8mm
1x11137	Screw Guide 80mm
1x1-1100101	Drill Bit d 4.8x180mm Coated - Quick Connect
1x91150	Bone Screw T Wrench

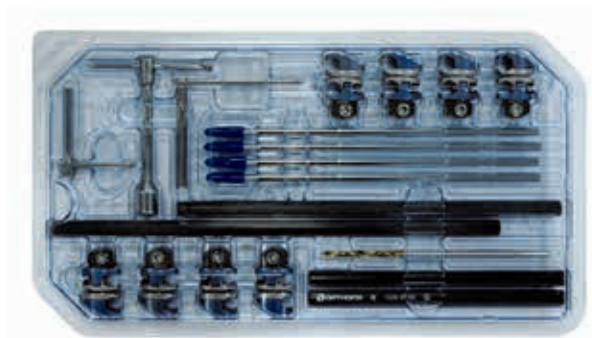

99-93502 Lower Limb Diaphyseal Sterile Kit

Consisting of:

Code	Description
6x93010	Large Clamp
1x932300	Rod d 12mm L 300mm
2x932150	Rod d 12mm L 150mm
2x912650	Self-drilling XCaliber Screws, L 260mm, thread length 50mm
2x911550	Self-drilling XCaliber Screws, L 150mm, thread length 50mm
1x11138	Drill Guide d 4.8mm
1x11137	Screw Guide 80mm
1x1-1100101	Drill Bit d 4.8x180mm Coated - Quick Connect
1x91150	Bone Screw T Wrench

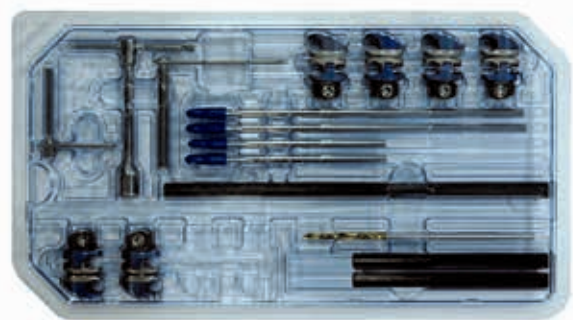

99-93503 Ankle Sterile Kit

Consisting of:

Code	Description
6x93010	Large Clamp
1x932300	Rod d 12mm L 300mm
1x932200	Rod d 12mm L 200mm
1x932150	Rod d 12mm L 150mm
2x911540	Self-drilling XCaliber Screws, L 150mm, thread length 40mm
1x11138	Drill Guide d 4.8mm
1x11137	Screw Guide 80mm
1x1-1100101	Drill Bit d 4.8x180mm Coated - Quick Connect
1x91150	Bone Screw T Wrench
1x93080	Transfix Pin 80mm - Shaft d.6mm/Thread d.7mm



**ANKLE STERILE KIT - TRANSFIX PIN Ø4mm
(99-93499)**

Can accommodate:

Code	Description
4x93010	Large Clamp
2x93030	Transitional Clamp
1x932300	Rod d 12mm L 300mm
1x932200	Rod d 12mm L 200mm
1x932150	Rod d 12mm L 150mm
2x911540	XCaliber Screws
1x11138	Drill guide d 4.8mm
1x11137	Screw Guide 80mm
1x1-1100101	Drill Bit d 4.8x180mm
1x91150	Universal "T" Wrench
1x92080	Transfix Pin thread length 80mm, thread Ø 5mm, shaft 4mm



**GALAXY MEDIUM - PAEDIATRIC STERILE KIT -
Ø5MM SCREW THREAD (99-93520)**

Code	Description
2x93140	Double multipin clamp medium
2x939250	Rod d 9mm L250mm
4x944540	Selfdrilling XCaliber Cylindrical Screw shaft Ø 6mm thread 5mm L150/40QC
2x11137	Screw guide 80mm
1x30017	Allen Wrench 5mm
1x93160	QC Wrench

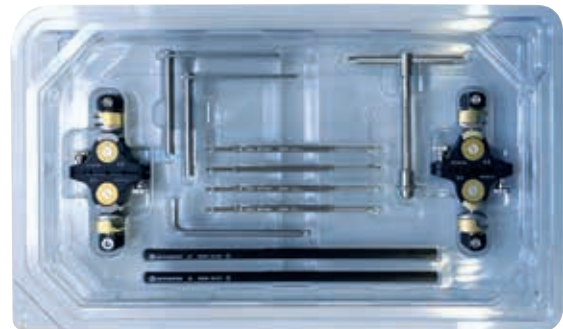

**GALAXY MEDIUM - PAEDIATRIC STERILE KIT -
Ø4MM SCREW THREAD (99-93521)**

Code	Description
2x93140	Double multipin clamp medium
2x939250	Rod d 9mm L250mm
4x944530	Selfdrilling XCaliber Cylindrical Screw shaft Ø 6mm thread 4mm L150/30QC
2x11137	Screw guide 80mm
1x30017	Allen Wrench 5mm
1x93160	QC Wrench

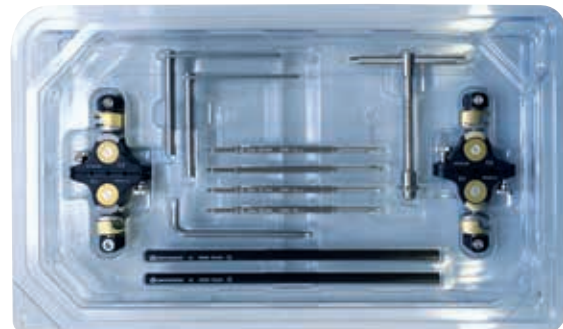

GENERAL INSTRUCTIONS

Screw Insertion

Screw positions should be planned with regard to zone of injury; often this may extend beyond the fracture lines visible on X-ray. Further thought into possible future surgeries, including plastic surgical and internal fixation procedures, should be given. X-rays of the fracture in two planes should be available. In general, screws should be placed anterolaterally in the femur; anteriorly (1 cm medial to the tibial crest in an anteroposterior direction) in the tibia; laterally in the proximal third of humerus and posterolaterally in the distal third of the humerus. Screws should be positioned for maximum mechanical stability in each bone segment, with bicortical purchase by the screw threads and with each pin as far apart in each segment as the fracture lines and neighbouring joints allow.

Insert two screws into each main fragment free-hand using the following technique:

1) Make a 15mm incision through skin and deep fascia. Use blunt dissection to reach the underlying bone (Fig. 1).

2) Insert a screw guide perpendicular to the longitudinal axis of the bone. Use a trocar to locate the midline by palpation (Fig. 2).

3) Keeping the screw guide in contact with the cortex by gentle pressure, withdraw the trocar, and tap the screw guide lightly to anchor the pronged end against bone (Fig. 3).

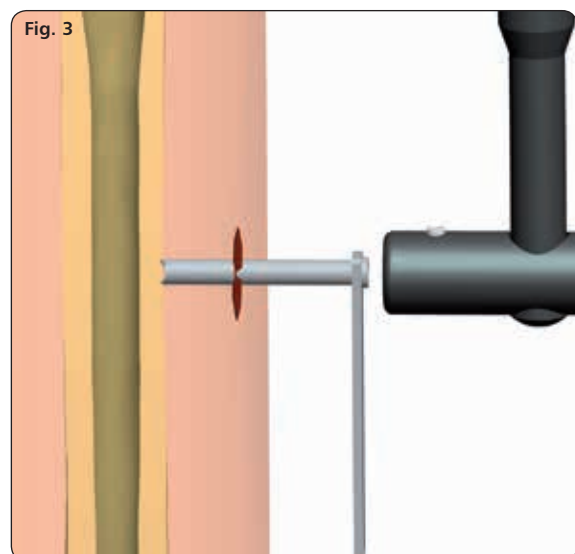
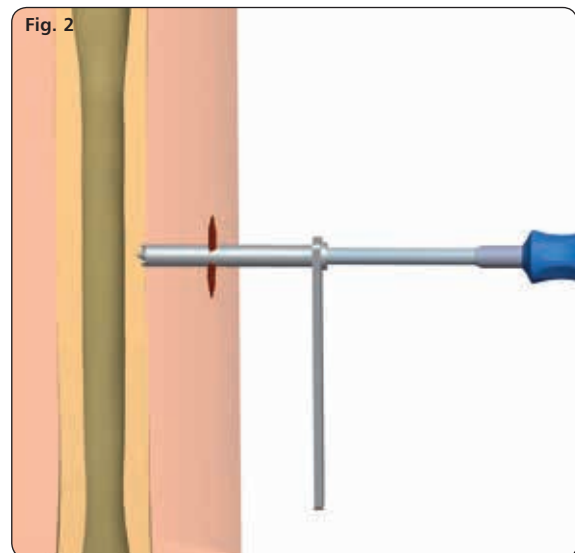
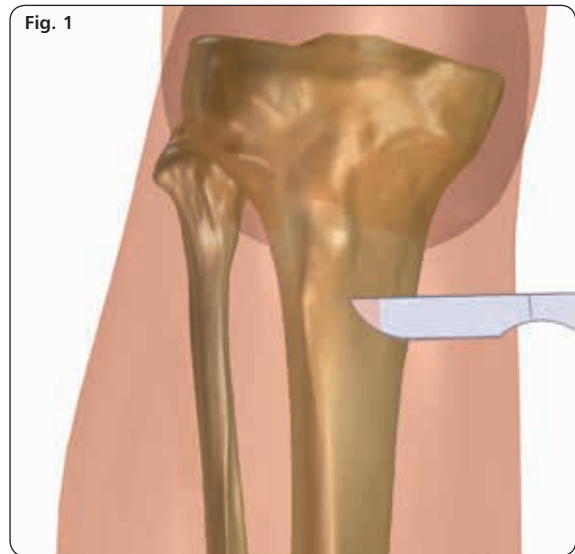

4) Insert a screw through the screw guide into the bone using the Hand Drill (Fig. 4a). While drilling, the hand drill should be held steady so that the drilling direction is maintained throughout the procedure. Once the second cortex has been reached, reduce the drilling speed; four more turns are needed so that the tip just protrudes through the distal cortex. Diaphyseal bone screws should always be inserted across the diameter of the bone to avoid off axis placement. Off axis location of screws may result in screw threads lying entirely within the cortex and not traversing the medullary canal; this may weaken the bone. In all cases the surgeon should be mindful of the amount of torque required to insert the screw. In general, it is safer drill a hole with a 4.8mm drill bit prior to insertion of these screws in diaphyseal bone(Fig. 4b).

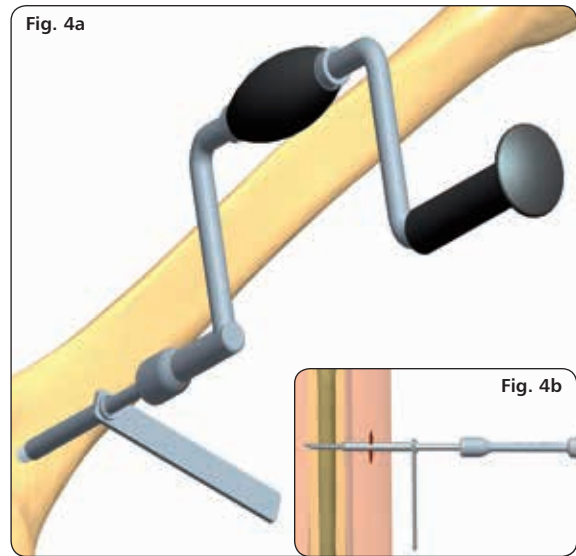

5) Insert the 4.8mm drill guide into the screw guide and introduce 4.8mm drill bit (Fig. 5). Drill at 500-600 rpm through the first cortex, checking that the drill bit is at right angles to the bone. The force applied to the drill should be firm and the drilling time as short as possible to avoid thermal damage. Once the second cortex has been reached, reduce the drilling speed and continue through the bone. Ensure that the drill bit completely penetrates the second cortex.

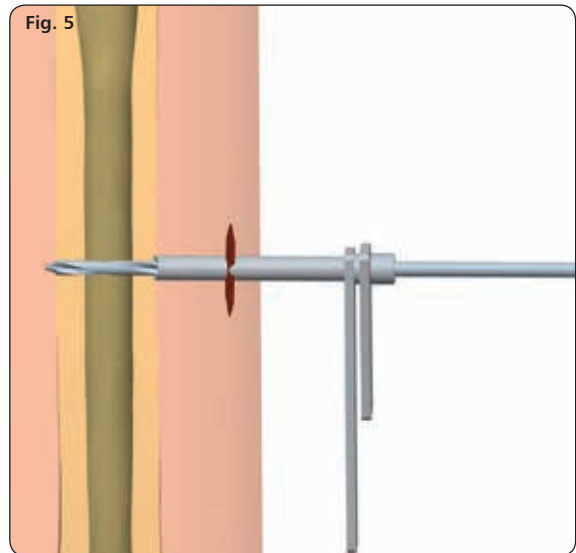

6) Remove the drill bit and drill guide, keeping pressure on the handle of the screw guide. The screw is inserted with the T-Wrench until it reaches the second cortex. A further 4-6 turns are required to ensure that about 2mm of the screw protrudes beyond the second cortex (Fig. 6).

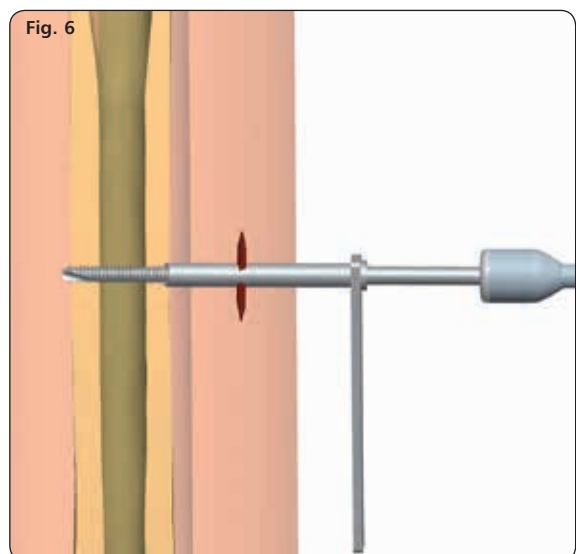

Note: The XCaliber self-drilling screws can be inserted by hand in cancellous bone. Pre-drilling is not often needed in this area. There is no need for the tip of the screw to protrude from the second cortex.

Warning! As the thread is tapered, repositioning the screw by turning counter-clockwise more than two turns will loosen the bone-screw interface.

XCaliber bone screw design

The threaded portion of the XCaliber bone screw tapers from 6.0mm to 5.6mm in diameter in order to provide an increasing radial preload during insertion. This maintains good fixation at the entry cortex which is usually the first area subject to problems of loosening. Despite the tapered profile, some adjustment of bone screw penetration is possible owing to the inherent elasticity of bone. However, the screws should not be backed out for more than two full turns. The screws have a pointed tip and flute which allow them to be inserted as self-drilling implants in cancellous bone without the need for pre-drilling. Direct insertion with a hand drill is advised in most situations, irrespective of whether uncoated or HA coated screws are used. However, when insertion of these self-drilling screws is performed in diaphyseal bone, pre-drilling is recommended; use a 4.8mm drill bit through a drill guide when the bone is hard. If the bone quality is poor or, as in the metaphyseal region, where the cortex is thin, a 3.2mm drill bit should be used.

XCaliber bone screws should never be inserted with a power tool. This may result in high temperatures and cell necrosis from too high insertion speeds. Screw insertion, whether or not pre-drilling has been performed, should always be with the XCaliber Hand Drill (91120) or Ratchet T Handle + Screw Shaft Connection (93150 + 93155). The screws have a round shank which is gripped securely by the XCaliber T-handle or Hand Drill. It is important that moderate force is applied initially for the screw to engage and gain entry into the first cortex.

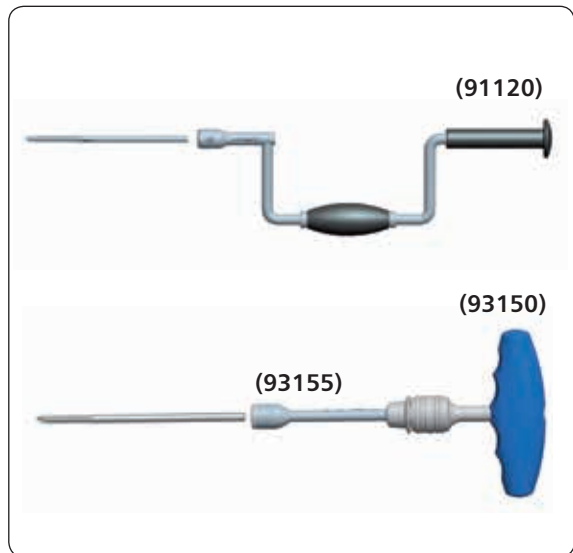

7) Tibial screws are preferentially inserted in the sagittal (anteroposterior) plane. Insert the remaining screws using the same technique (Fig. 7).

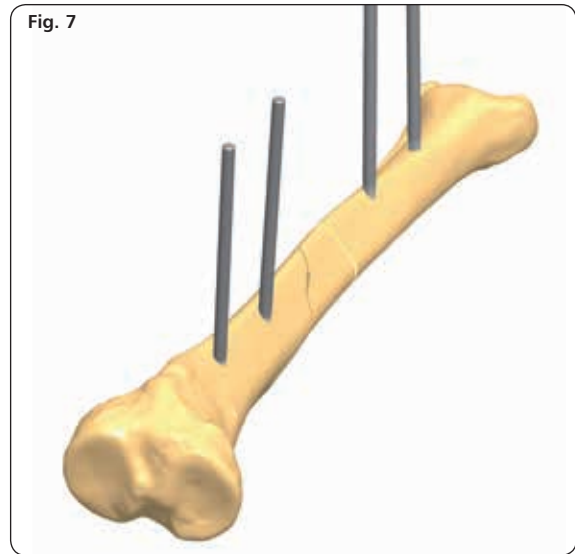

Fixator Application

8) The two screws in each bone segment are joined by rods of suitable length; each one mounted with two clamps positioned about 30mm from the skin. They are then locked manually by turning the knurled metal ring clockwise (Fig. 8).

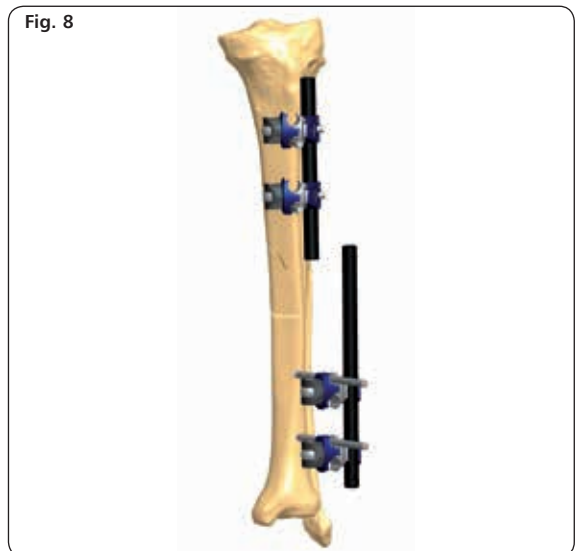

9) A third rod is then used to join the first two rods together by 2 more clamps, which are not yet tightened. The surgeon now manipulates the fracture, if possible under X-ray control. When the position is satisfactory, the assistant locks all the clamps firmly by tightening the cams with the Universal T-Wrench or the 5mm Allen Wrench (Fig. 9).

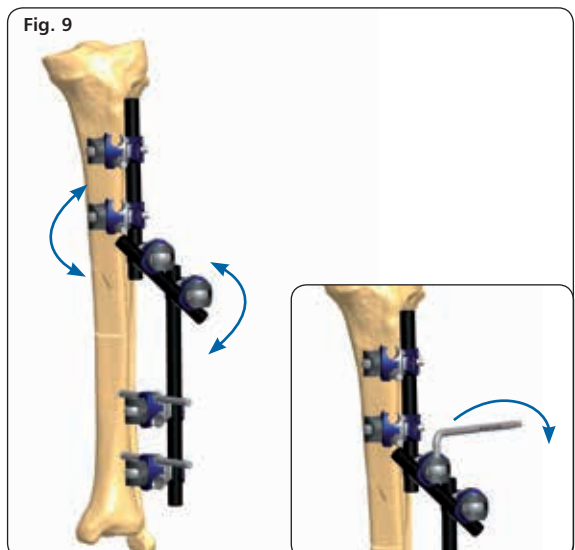

10) The screw shafts are then cut with the bone screw cutter (Fig. 10). Although the screws can be cut before insertion, it is difficult to gauge the length accurately, and it is recommended that they are cut after the fixator has been applied. It is important that all of the screws are inserted first, and the fixator applied with the clamps locked firmly over the screws, about 30mm from the skin. The cutter can then be slid over the screw shanks in turn and the screws cut close to the fixator clamps. This will normally result in about 6mm of screw shank protruding from the clamp. The cutter is designed so that it can be used even when screws are in adjacent seats of the multi-screw clamp. The cut ends of the screws can then be protected with screw caps. When cutting the screws, the arms of the cutter should be extended for greater efficiency and the outer end of the screw held.

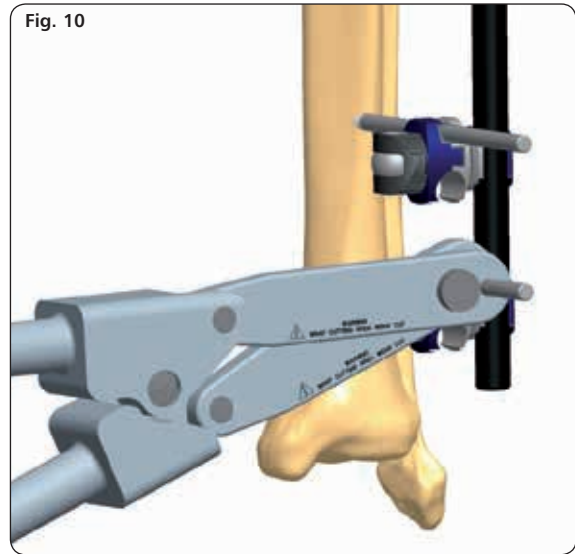

MULTI-SCREW CLAMPS

Insert the first screw into one of the outer holes of the multi-screw clamp guide using the same technique as described above. Insert the second screw in the remaining outer seat and cut both screw shafts with the bone screw cutter. Lastly, insert the central screw if necessary.

Option 1

Use the multi-screw clamp as a template to insert screws perpendicular to the longitudinal axis of the bone (Fig. 11).

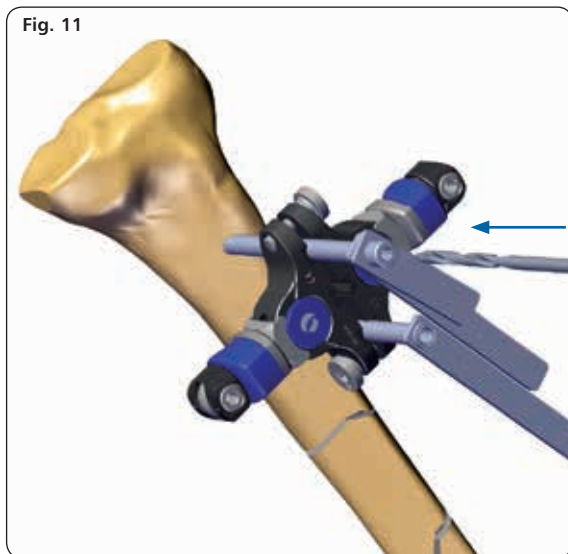

Option 2

Use the Multi-Screw Clamp Guide 19940 as a template to insert screws perpendicular to the longitudinal axis of the bone (Fig. 12).

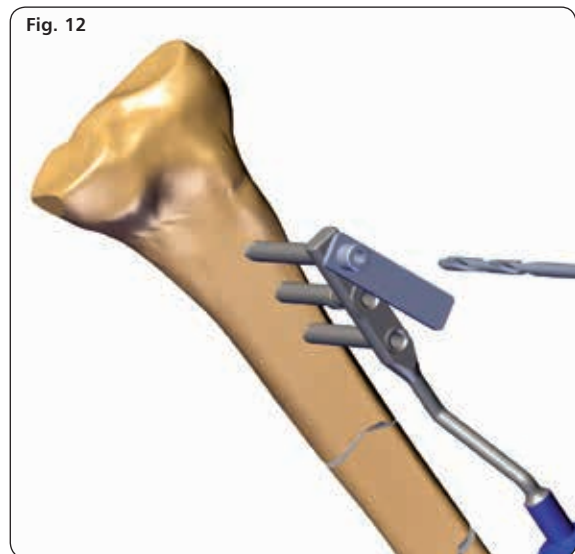

APPLICATION BY ANATOMICAL SITE

The external fixator assemblies described in this manual are suggested configurations in order to achieve stability through the optimal use of components and efficiency in application. Each fixator configuration for each anatomical site can conveniently be linked to the adjacent region; this is the rationale for the choice of screw position and rod connections. In so doing, the surgeon can perform damage control stabilisation from pelvis to foot with familiarity of one fixator configuration for each anatomical region.

FEMORAL APPLICATION

In the femur, screws can be inserted within an arc of 30 degrees on either side of the coronal plane, i.e. from 30 degrees postero-lateral to 30 degrees antero-lateral. In damage control scenarios, the anterolateral plane is recommended. This facilitates:

- a. Easy connection to tibial assembly in order to span the knee securely.
- b. Sufficient clearance to enable lateral submuscular plating of the femur to be accomplished, should this be the desired conversion to definitive stabilisation.

Damage control configuration for distal periarticular fracture of the femur or tibia.

The femoral screws are anterolateral whereas the tibial ones sagittal. The femoral rod is attached laterally and the tibial rod medially to the screws. An oblique cross connection with a third rod is made. Additional screws can be inserted from this cross connecting rod into the distal femur or proximal tibia.

KNEE AND TIBIA APPLICATION

Screw insertion in the tibia is within the safe corridors illustrated in the cross-sections. The anteroposterior screw is inserted 1cm medial to the crest of the tibia; screw insertion through the crest carries the risk of thermal necrosis during drilling due to the thickness of this part of the tibia and is not recommended. If bi-planar stability is desired, the angles shown in the diagrams indicate the spread of screw position possible at each level. Screws should not be inserted through the lateral side or anterior compartment except for the proximal one quarter (the tibia plateau and adjacent metaphyseal region). If possible, screws should avoid the region just distal to the lower margin of the tibial tuberosity as this is the preferred location of the osteotomy for bone transport or lengthening should this be deemed necessary in the reconstruction of the tibia. Anteroposterior screws in the tibia facilitate lateral submuscular plating if this is the chosen definitive treatment.

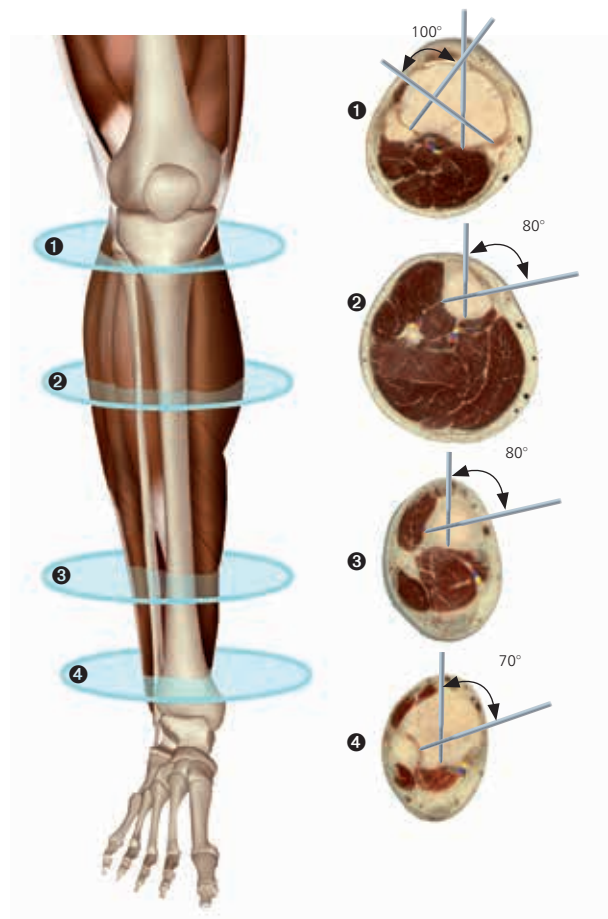
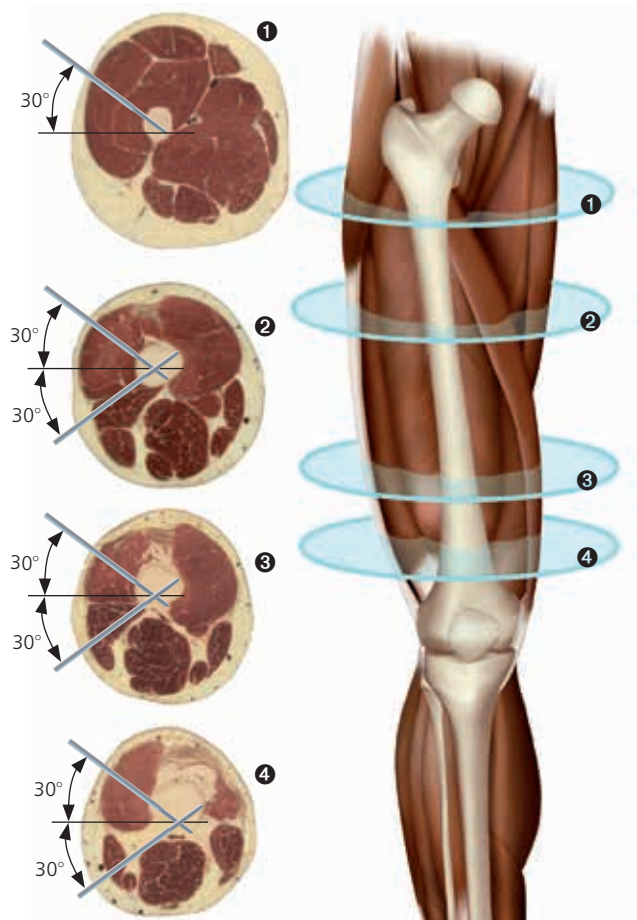

FEMUR



KNEE



TIBIA



ANKLE



PAEDIATRICS APPLICATIONS

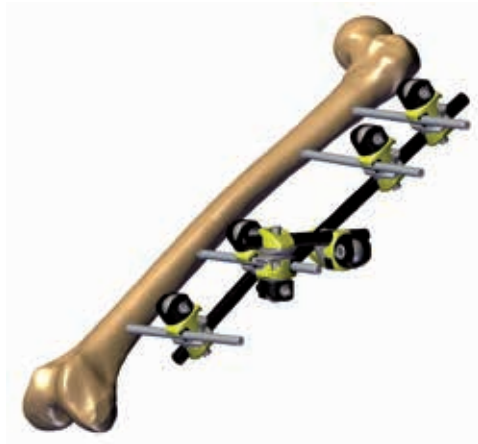

PELVIS APPLICATION

There are two recommended options for screw placement in the pelvis.

Supra-acetabular (Anterior) screw placement

Given the wider cross sectional area and better bone purchase, the more technically difficult supra-acetabular screw placement is preferred over that of the iliac crest. Proceeding from the anterior superior iliac spine, the site of entry is approximately 4-6 cm in a caudal direction. A skin incision of about 3-4 cm is made and the subcutaneous tissue divided by blunt dissection to preserve the lateral cutaneous nerve of the thigh. The bone at the anterior inferior iliac spine is exposed and the screw guide placed firmly on the bone. The first 5-8mm of the self-drilling screw is tapped into the bone and then advanced gradually between the inner and outer cortical tables of the ilium, inclined about 15°-20° in a cranial direction and 30° internally with the patient supine on the table.

Iliac crest (Superior) screw placement

To prevent damage to the lateral cutaneous nerve of the thigh, avoid insertion less than 20mm posterior to the anterior superior iliac spine. The iliac crest can easily be palpated. Adequate bone substance for screw insertion is only found in the anterior part of the iliac crest, from 2 cm to 7 cm posterior to the anterior superior iliac spine. The screws should be directed towards the acetabulum and should follow the route between the outer and inner table of the ilium.

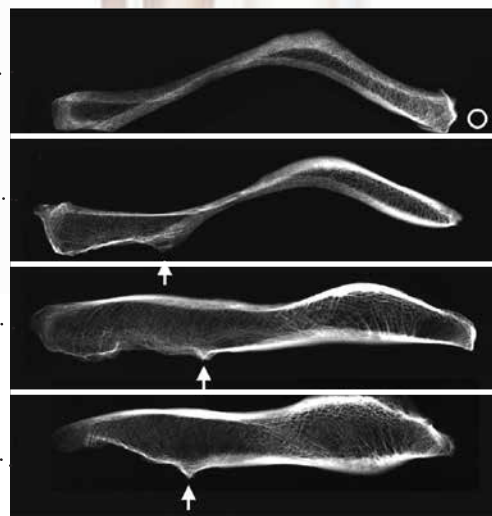
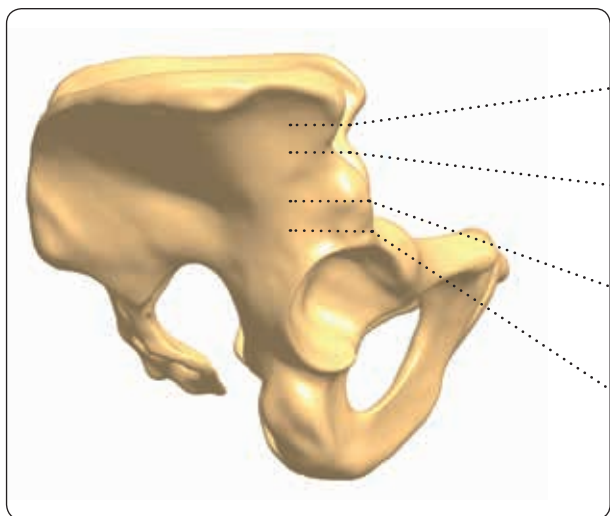
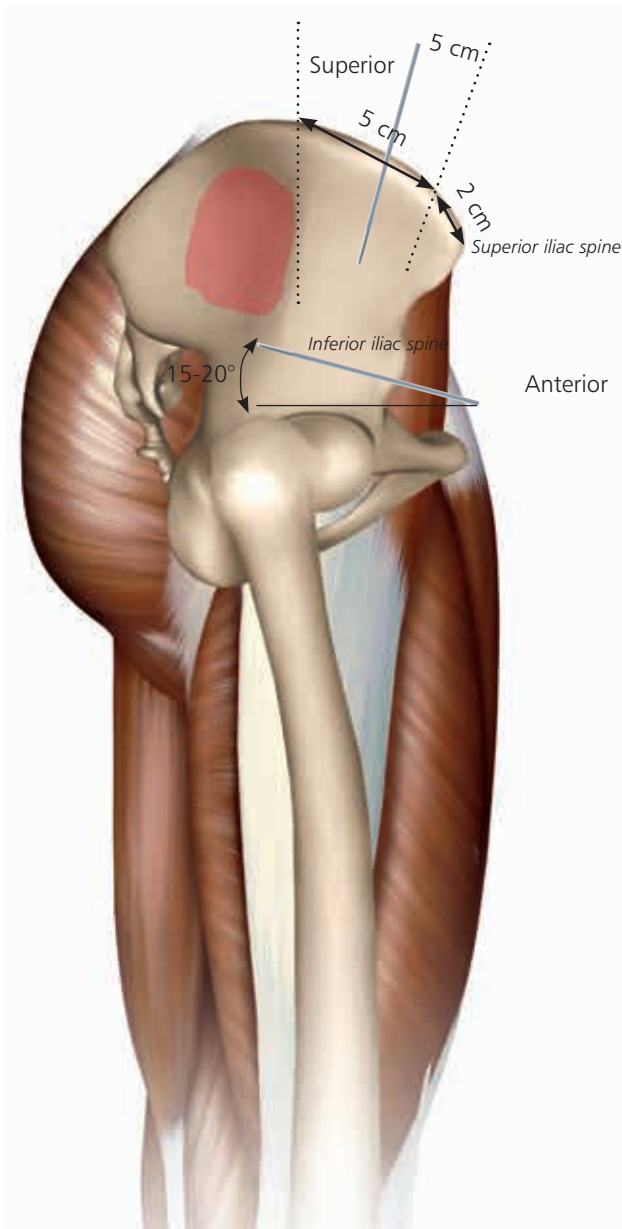

There are two main planes of instability: a horizontal plane and a vertical plane. Based upon this, pelvic ring instability may be divided into three types according to Tile's classification, which indicate the type of management required. Type A injuries are stable and external fixation is therefore indicated only in Type

B and C fractures to stabilise the anterior rotational instability. It is important to note that an anteriorly placed external fixator ONLY addresses this component of the instability; any component of the instability arising from posterior elements of the pelvic ring will require other methods of stabilisation.

Type B - Rotationally unstable but vertically stable

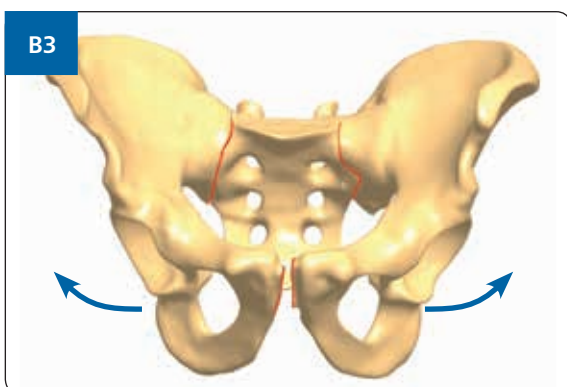
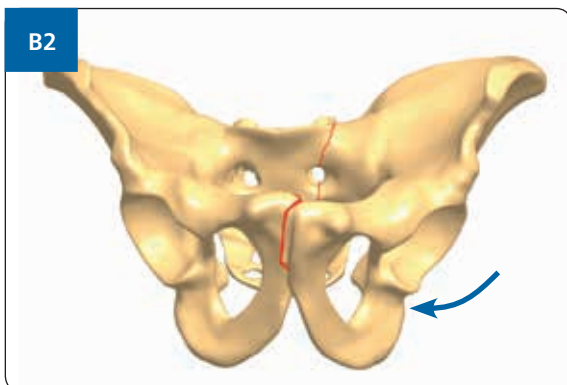
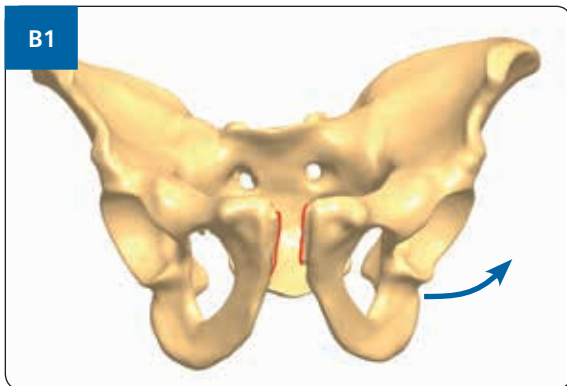

Type C - Rotationally and vertically unstable

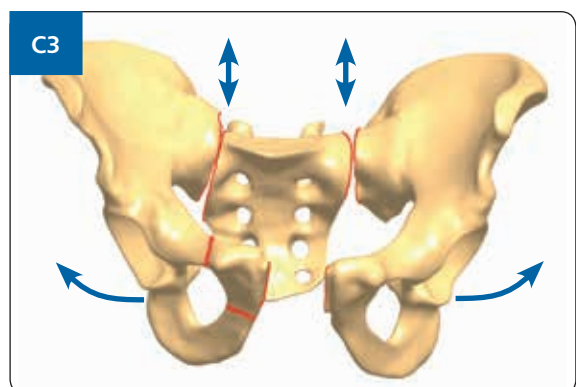
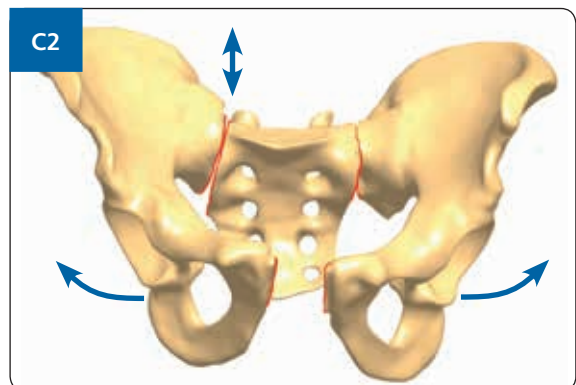
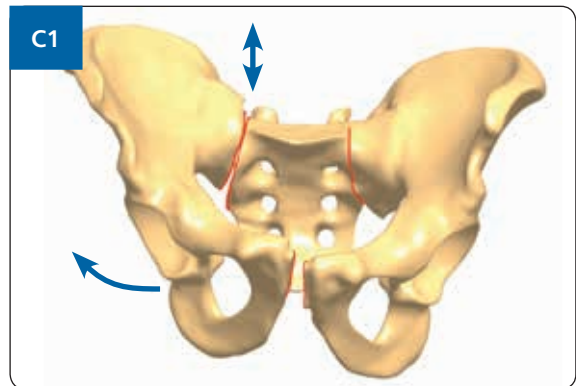

ANTERIOR APPLICATION

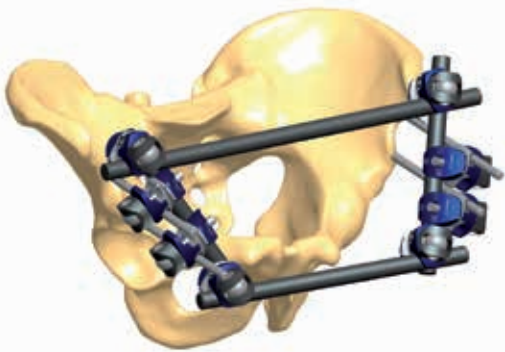

ILIAC CREST APPLICATION

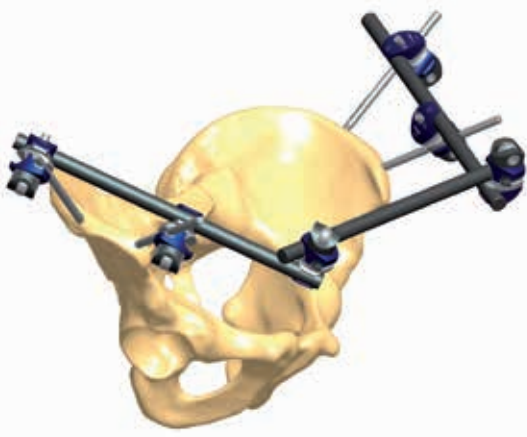

HYBRID APPLICATION

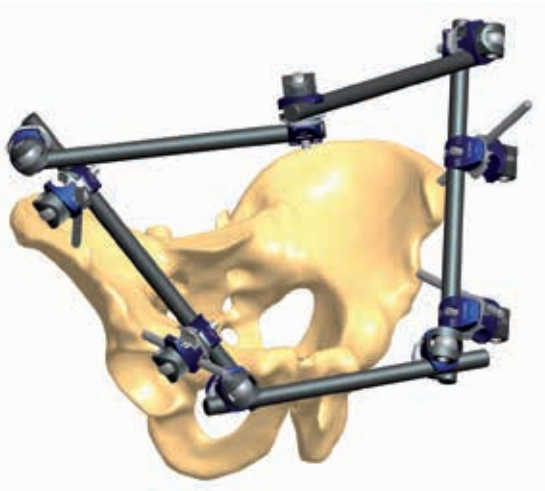

In **type B1** and **B3** injuries a diastasis of the symphysis greater than 2.5 cm indicates a severe rotational instability and an increased pelvic volume. Therefore an external fixator is applied as an emergency procedure to reduce the pelvic volume and stop bleeding. However, the true instability in this "open book" fracture cannot securely be estimated by the AP X-ray. Clinical investigation (i.e. by testing stability manually) is mandatory for the indication of immediate external fixation.

In **type B2** injuries external fixation is rarely necessary as an emergency procedure because the impaction of the fracture site leads to a sufficient stability and there is no increased pelvic volume. CT investigation may clarify the true fracture pattern and subsequently the correct treatment protocol, and is also recommended to evaluate the posterior structures (sacro-iliac joint, sacrum, posterior part of iliac bone).

Type C injuries are always considered unstable. In the emergency situation the fixator is used on the anterior side of the pelvic ring with screws either in the supra-acetabular region and/or at the iliac crest to increase stability. The posterior part of the pelvic ring cannot be fully controlled by the external fixator in terms of weight bearing. Nevertheless, external fixation allows enough stability to reduce the pelvic volume and therefore the amount of bleeding. After resuscitation of the patient and further investigation, subsequent internal fixation of the posterior part of the pelvic ring may be considered.

Fig. 1

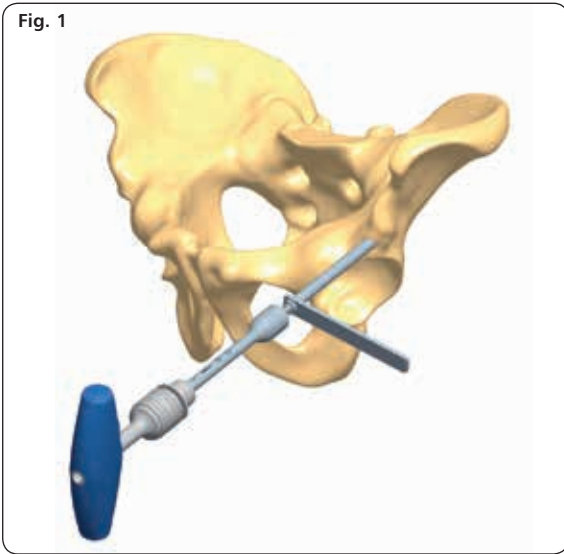

Fig. 2

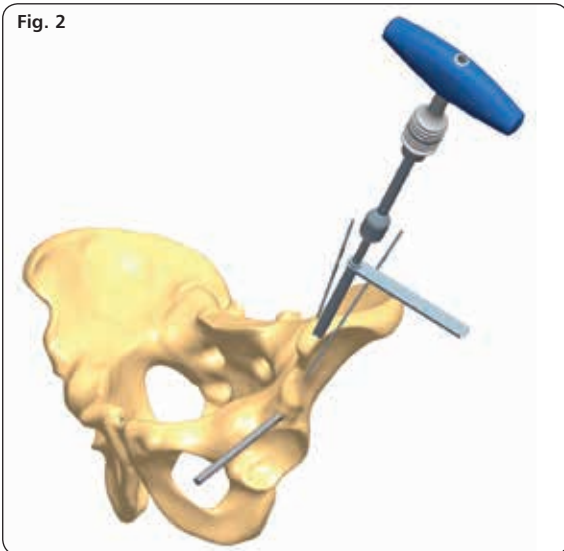
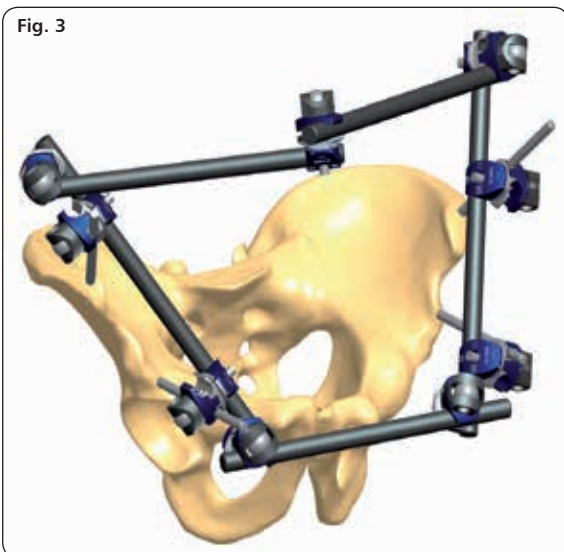

Fig. 3



OPERATIVE TECHNIQUE

1) Commence with the uninjured side. Make an incision just caudal to the anterior superior iliac spine to course over the anterior inferior iliac spine. Identify the lateral edge of Sartorius muscle and retract medially. The rounded tendinous portion of rectus femoris can be seen arising from the anterior inferior iliac spine. Make an incision down to bone just cranial to this spine. Roughen this area with a periosteal elevator. Tap a self-drilling screw 5-8mm into the roughened area in order to engage the bony cortex and advance the screw using turns of the T-handle. Aim the screw 15-20 degrees cranial to avoid penetration of the hip joint and to enter the widest part of the ilium (Fig. 1).

2) Insert two Kirschner wires to establish the orientation of the hemipelvis: one from the iliac crest along the inner table of the ilium and one along the outer table (Fig. 2). Insert a self-drilling screw, gently tap it through the cortex and screw it home with the T-wrench, without forcing the screw in any direction. The depth of insertion is 40-50mm (almost the entire thread length). In young patients (16 years and under), use a 3.2mm drill bit and drill guide to penetrate the hard cortex to a depth of 1 cm. Screws in the iliac crest should be inserted in a region from 2 cm to 7 cm posterior to the anterior superior iliac spine. These screws should be directed towards the acetabulum and should follow the route between the outer and inner table of the ilium.

3) The two screws in each hemipelvis are joined by rods of suitable length, each one mounted with 2 clamps. They are then locked manually by turning the knurled metal ring clockwise. Two rods are then used to link the first two rods across the width of the pelvis (this can be at two levels as shown in Fig. 3) through use of additional clamps which are attached but not yet tightened. The surgeon now manipulates the fracture, if possible under X-ray control; when the position is satisfactory, the assistant locks the clamps firmly by tightening the cams clockwise with the Universal T-Wrench or the 5mm Allen Wrench (Fig. 3).

DAMAGE CONTROL

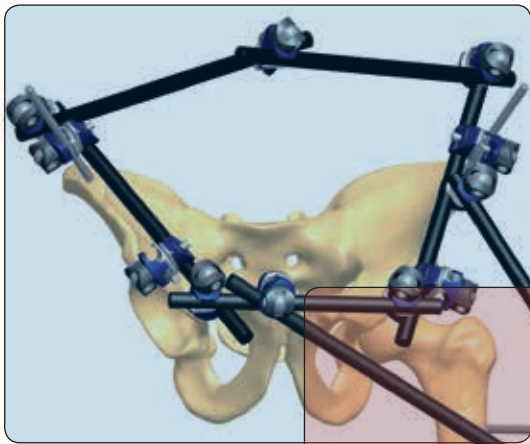

Pelvic application for unstable open book injuries

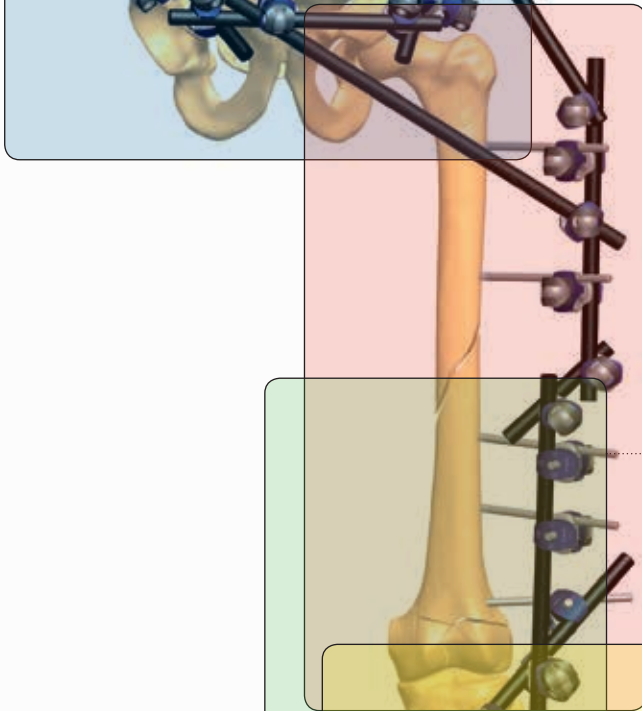

Femoral application for diaphyseal fractures

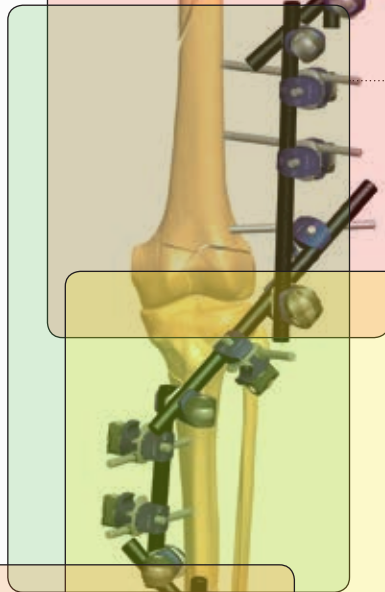

Knee spanning configuration for periarticular fractures or ligamentous injuries of the knee

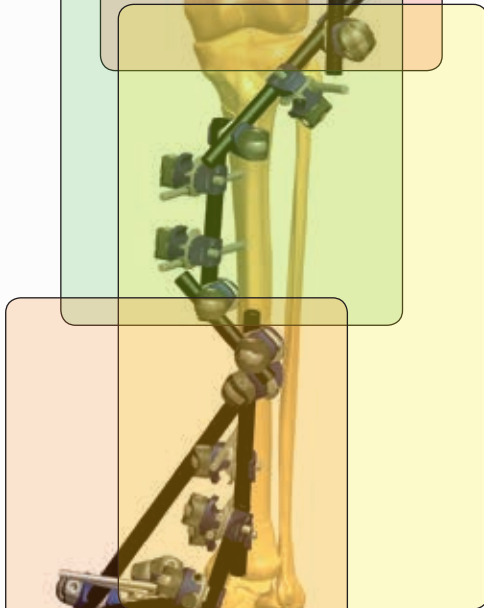

Tibial application for diaphyseal fractures



Ankle spanning configuration for periarticular fractures or ligamentous injuries

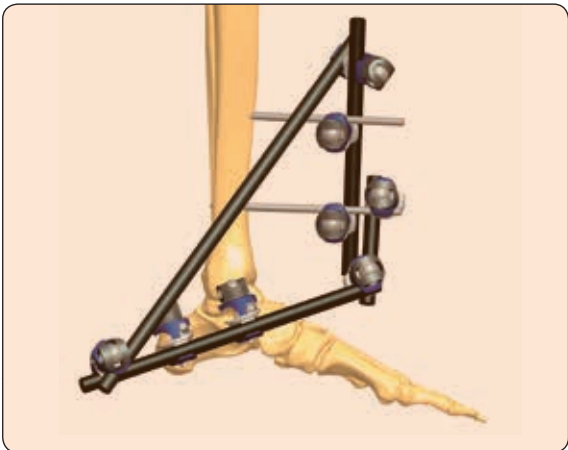
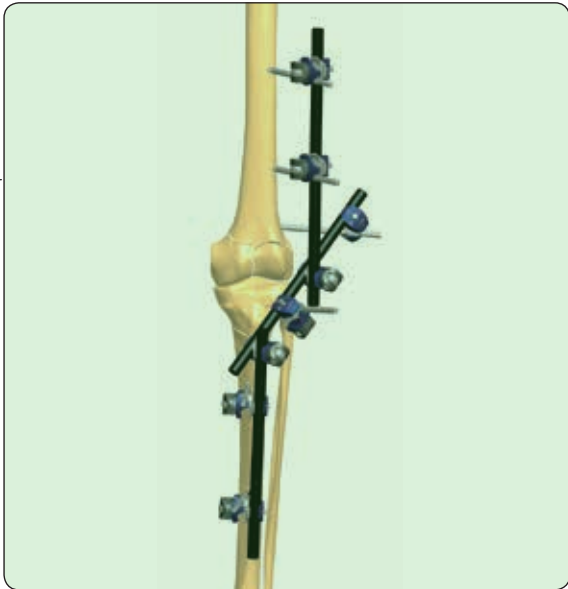
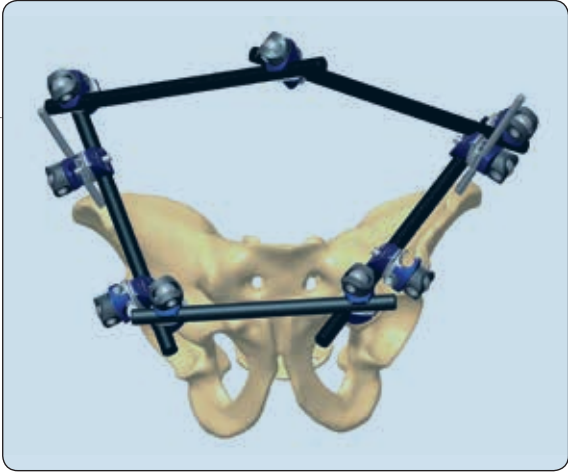

KEY PRINCIPLES FOR STABILITY IN EXTERNAL FIXATION

N. Giotakis • B. Narayan. Stability with unilateral external fixation in the tibia. Strat Traum Limb Recon (2007) 2:13–20

Three variables which directly influence the stability of the external fixator are:

- The bone–pin interface
- The components of the fixator
- The fixator configuration

The bone-pin interface

Two important parameters that influence interface stresses and bone hold are pin diameter and interference. Larger diameter pins have a higher resistance to bending forces. This in turn can reduce the stresses at the bone–pin interface. The limit to increasing pin size is set by the diameter of the bone in which the pin is inserted. In practice it is advisable to keep pin sizes to within a third of the diameter of the bone to reduce the risk of fracture on removal of the halfpin.

Interference is a measure of the ‘grip’ the pin has on Bone. Maximising interference at the beginning serves to promote bone hold for longer. However this cannot be achieved by simply reducing the size of the pilot drill hole and increasing the major diameter of the pin; such a situation can lead to micro fractures, or crack propagation when the pin is forced into a small pilot hole.

The components of the fixator

Fixator components are:

1. pin and rod clamps
2. connecting bars

It is the responsibility of the surgeon to ensure the clamps are tightened very securely when the fixator has been applied as loose clamps are not infrequently responsible for loss of fracture control.

Connecting bars are available in different diameters and lengths. The diameter of the bar used is important; stiffness increases with the fourth power of the radius.

Double stacking the bars improves bending stiffness in the plane of the half pins but does not increase stability in the orthogonal plane or improve resistance to torsion (Fig. A).

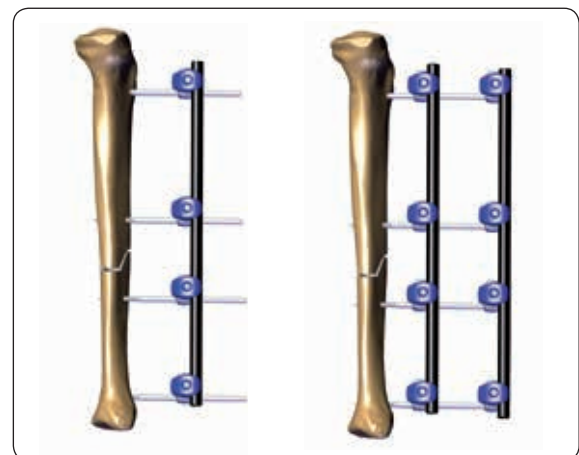
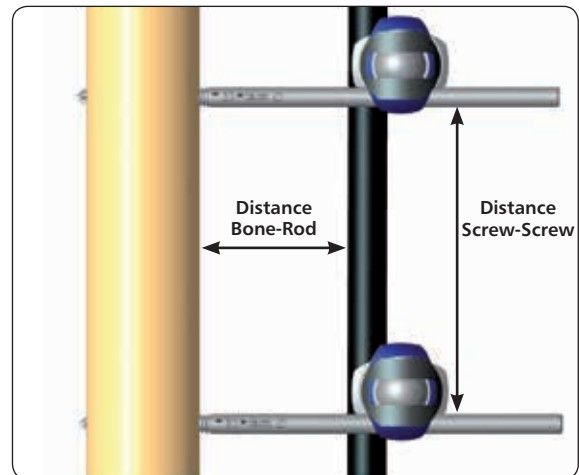

Fig. A

The fixator configuration

The way by which the fixator is assembled can change stability through:

1. the number and spread of pins along the segments, and
2. the distance between connecting rods and bone

According to the general principles of external fixation, an increase in stiffness is provided by increasing pin number from two to three in any one segment. The added benefit from increasing pin number from three to four is minimal, therefore three pins per segment is advised. The external fixator configuration will depend on the amount of bone contact at the fracture site, the fracture pattern and the segment or segments of bone involved. This manual provides examples of how fixator configuration can be augmented in some common fracture patterns to create stability sufficient to allow rehabilitation of the patient. As for pin spread, the 'near and far' rule provides a guide; pins should be spread along a segment of bone such that the segment is spanned. The proximity of any pin to the fracture itself is cautioned as the pin may be within the fracture haematoma and thereby carry the risk of a pin site infection spreading to within the fracture. A rule of thumb of staying at least 2 cm from the nearest fracture line helps (Fig. B).

The distance of the connecting bar from bone is determined by the depth of soft tissue in between. Bringing the connecting bar closer to bone improves stability and in general it should be kept as close as possible with enough room to facilitate pin site care - 40- 50mm (roughly 2 finger breadths) from the bone surface if feasible (Fig. C).

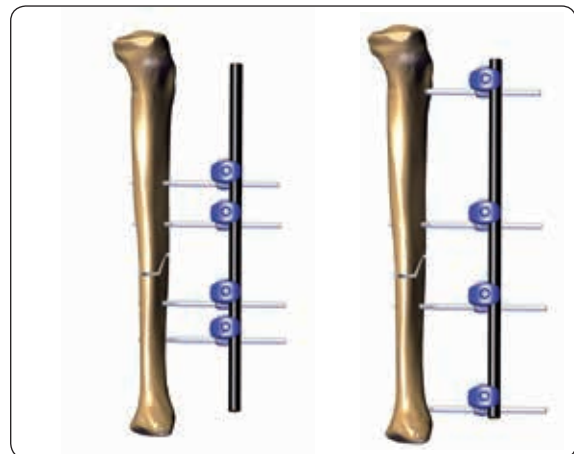

Fig. B

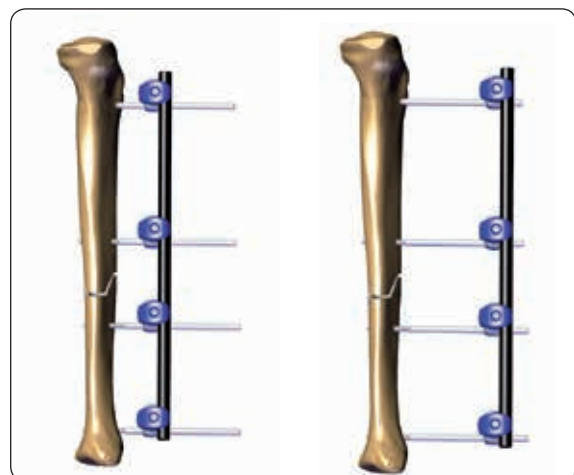

Fig. C

Biplanar Unilateral Configuration

Additional stability can be achieved with a biplanar unilateral configuration, which has particular advantages for control of bending in both sagittal and coronal planes (and in planes in between) as well as high resistance against torsion.



MRI INFORMATION

Galaxy System Fixator Components are labeled MR CONDITIONAL  according to the terminology specified in ASTM F2503 Standard Practice for Marking Medical Devices and Other Items in the Magnetic Resonance Environment.

Non-clinical testing has demonstrated that the Galaxy System Fixator Components is MR Conditional according to the terminology specified in ASTM F2503 Standard Practice for Marking Medical Devices and Other Items in the Magnetic Resonance Environment. Non-clinical testing, done according to ASTM F2052-06, F2213-06, F2182-11, F2119-07, demonstrated that a patient with the Galaxy Fixation™ System can be safely scanned under the following conditions:

- Static magnetic field of 1.5 Tesla and 3.0Tesla
- Maximum spatial magnetic field gradient of 900-Gauss/cm (90mT/cm)
- Maximum whole-body-averaged specific absorption rate (SAR) of 4.0 W/kg in the First Level Controlled Mode for 15 minutes of scanning.
- No local transmit/receive coils must be used on the device.
- The Galaxy Fixation System must be entirely outside the MR scanner bore.

No part of the Galaxy Fixation System must extend into the MR bore. Therefore MR scanning of body parts where the Galaxy Fixation System is located is Contraindicated.

Displacement Information

The system will not present an additional risk or hazard to a patient in the 1.5Tesla and 3Tesla MR environment with regard to translational attraction or migration and torque.

Heating Information

Comprehensive electromagnetic computer modeling and experimental testing was performed on the following systems:

1.5-Tesla/64-MHz: Magnetom, Siemens Medical Solutions, Malvern, PA. Software Numaris/4, Version Syngo MR 2002B DHHS Active-shielded, horizontal field scanner

3-Tesla/128-MHz: Excite, HDx, Software 14X.M5, General Electric Healthcare, Milwaukee, WI, Active-shielded, horizontal field scanner to determine the worst heating in seven configurations of Orthofix Galaxy Fixation System. From these studies, it is concluded that once the entire external fixation frame is visible outside the MRI bore, the maximum heating is less than 2 degree Celsius. In non-clinical testing the worst scenarios produced the following temperature rises during MRI under the conditions reported above:

	1.5 Tesla System	3.0 Tesla System
Galaxy Fixation™ System		
Minutes of scanning	15	15
Calorimetry measured values, whole body averaged SAR (W/kg)	2.2 W/Kg	2.5 W/Kg
Highest temperature Rise less than (°C)	2 C	2 C

Please note that temperature changes reported apply to the designed MR systems and characteristics used. If a different MR system is used, temperature changes may vary but are expected to be low enough for safe scanning as long as all Galaxy System Fixator Components are placed **outside** the MR bore.

MR PATIENT SAFETY

MRI in patients with Galaxy Fixation System can only be performed under these parameters. It is not allowed to scan the Galaxy Fixation System directly. Using other parameters, MRI could result in serious injury to the patient. When the Galaxy Fixation System is used in conjunction with other External Fixation Systems please be advised that this combination has not been tested in the MR environment and therefore higher heating and serious injury to the patient may occur. Because higher in vivo heating cannot be excluded, close patient monitoring and communication with the patient during the scan is required. Immediately abort the scan if the patient reports burning sensation or pain.

Galaxy Fixation System can only be guaranteed for MRI when using the following components to build a frame:

NOTE: *the following components are listed in non-sterile configuration. Please consider that the same MRI information and performance are applicable to the same components in gamma-sterile configuration, code number preceeded by 99- (e.g 99-93030).

References

- 1) Summary, conclusions and recommendations: adverse temperature levels in the human body. Goldstein L.S., Dewhirst M.W., Repacholi M., Kheifets L. Int. J. Hyperthermia Vol 19 N. 2003 pag 373-384.
- 2) Assessment of bone viability after heat trauma Eriksson R.A., Albrektsson T., Magnusson B. Scand J Plast Reconst Surg 18:261-68 1984.
- 3) Temperature threshold levels for heat-induced bone tissue injury: A vital-microscopic study in the rabbit Eriksson A.R., Albrektsson T. J Prosthet Dent. 1983 Jul;50(1):101-7.

RODS*

Code	Description
932100	Rod 100mm long, 12mm diameter
932150	Rod 150mm long, 12mm diameter
932200	Rod 200mm long, 12mm diameter
932250	Rod 250mm long, 12mm diameter
932300	Rod 300mm long, 12mm diameter
932350	Rod 350mm long, 12mm diameter
932400	Rod 400mm long, 12mm diameter
99-932450	Rod 450mm long, 12mm diameter, sterile**
99-932500	Rod 500mm long, 12mm diameter, sterile**
99-932550	Rod 550mm long, 12mm diameter, sterile**
99-932600	Rod 600mm long, 12mm diameter, sterile**
99-932650	Rod 650mm long, 12mm diameter, sterile**
939100	Rod 100mm long, 9mm diameter
939150	Rod 150mm long, 9mm diameter
939200	Rod 200mm long, 9mm diameter
939250	Rod 250mm long, 9mm diameter
939300	Rod 300mm long, 9mm diameter
936060	Rod 60mm long, 6mm diameter
936080	Rod 80mm long, 6mm diameter
936100	Rod 100mm long, 6mm diameter
936120	Rod 120mm long, 6mm diameter
936140	Rod 140mm long, 6mm diameter
936160	Rod 160mm long, 6mm diameter
936180	Rod 180mm long, 6mm diameter
936200	Rod 200mm long, 6mm diameter

CLAMPS*

Code	Description
93010	Large Clamp
93110	Medium Clamp
93310	Small Clamp
93020	Multi-screw Clamp
93030	Large-Medium Transition Clamp
93120	Medium Multi-screw Clamp
99-93040	Large Double Multiscrew Clamp
99-93140	Medium Double Multiscrew Clamp

ELBOW HINGE*

Code	Description
93410	Elbow Hinge

XCALIBER BONE SCREWS*

Code	Shaft Ø	Thread Ø	Total L	Thread L
912630	6	6 - 5,6	260	30
912640	6	6 - 5,6	260	40
912650	6	6 - 5,6	260	50
912660	6	6 - 5,6	260	60
912670	6	6 - 5,6	260	70
912680	6	6 - 5,6	260	80
912690	6	6 - 5,6	260	90
911530	6	6 - 5,6	150	30
911540	6	6 - 5,6	150	40
911550	6	6 - 5,6	150	50
911560	6	6 - 5,6	150	60
911570	6	6 - 5,6	150	70
911580	6	6 - 5,6	150	80
911590	6	6 - 5,6	150	90

BONE SCREWS*

Code	Shaft Ø	Thread Ø	Total L	Thread L
10190	6	4,5 - 3,5	70	20
10191	6	4,5 - 3,5	80	20
10108	6	4,5 - 3,5	80	30
10135	6	4,5 - 3,5	100	20
10136	6	4,5 - 3,5	100	30
10105	6	4,5 - 3,5	100	40
10137	6	4,5 - 3,5	120	20
10138	6	4,5 - 3,5	120	30
10106	6	4,5 - 3,5	120	40
35100	4	3,3 - 3	70	20
35101	4	3,3 - 3	80	35

GALAXY TL-HEX CONNECTING POSTS

Code	Description
93031	Galaxy TL-HEX Connecting Post L50mm D12mm
93032	Galaxy TL-HEX Connecting Post L100mm D12mm

XCALIBER CYLINDRICAL BONE SCREWS*

Code	Shaft Ø	Thread Ø	Total L	Thread L
942630	6	6	260	30
942640	6	6	260	40
942650	6	6	260	50
942660	6	6	260	60
942670	6	6	260	70
942680	6	6	260	80
942690	6	6	260	90
941630	6	6	180	30
941640	6	6	180	40
941650	6	6	180	50
941660	6	6	180	60
941670	6	6	180	70
941680	6	6	180	80
941690	6	6	180	90
942540	6	5	260	40
942550	6	5	260	50
942560	6	5	260	60
942570	6	5	260	70
942580	6	5	260	80
942590	6	5	260	90
943540	6	5	220	40
943550	6	5	220	50
943560	6	5	220	60
943570	6	5	220	70
941540	6	5	180	40
941550	6	5	180	50
941560	6	5	180	60
944530	6	5	150	30
944535	6	5	150	35
944540	6	5	150	40
944550	6	5	150	50
945530	6	5	120	30
945535	6	5	120	35
945540	6	5	120	40
946420	6	4	180	20
946430	6	4	180	30
946440	6	4	180	40
945420	6	4	150	20
945430	6	4	150	30
945440	6	4	150	40
944420	6	4	120	20
944430	6	4	120	30
944440	6	4	120	40
943420	6	4	100	20
943430	6	4	100	30
943440	6	4	100	40
948320	4	3	120	20
948325	4	3	120	25
948335	4	3	120	35
947320	4	3	100	20
947325	4	3	100	25
M310	3	3 - 2,5	50	18
M311	3	3 - 2,5	60	20
M312	3	3 - 2,5	60	25
M313	3	3 - 2,5	60	30
M321	3	3 - 2,5	70	15
M314	3	3 - 2,5	70	20
M315	3	3 - 2,5	70	25
M316	3	3 - 2,5	70	30
M317	3	3 - 2,5	100	30

The Orthofix Galaxy Fixation System components not listed above have not been tested for heating, migration, or image artifact in the MR environment, and their safety is unknown. Scanning a patient carrying a frame that includes these components may result in patient injury.

* Products may not be available in all markets because product availability is subject to the regulatory and/or medical practices in individual markets. Please contact your Orthofix representative if you have questions about the availability of Orthofix products in your area.

** Special order only.

Electronic Instructions for use available at the website
<http://ifu.orthofix.it>

Electronic Instructions for use - Minimum requirements for consultation:

- Internet connection (56 Kbit/s)
- Device capable to visualize PDF (ISO/IEC 32000-1) files
- Disk space: 50Mbytes

Free paper copy can be requested to customer service (delivery within 7 days):
tel +39 045 6719301, fax +39 045 6719370,
e-mail: customerservice@orthofix.it

Distributed by:

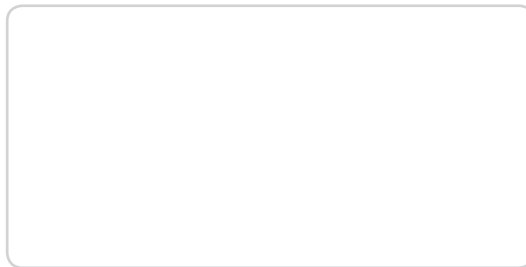

Manufactured by:
ORTHOFIX Srl
Via Delle Nazioni 9, 37012 Bussolengo (Verona), Italy
Telephone +39 045 6719000, Fax +39 045 6719380



Caution: Federal law (USA) restricts this device to sale by or on the order of a physician. Proper surgical procedure is the responsibility of the medical professional. Operative techniques are furnished as an informative guideline. Each surgeon must evaluate the appropriateness of a technique based on his or her personal medical credentials and experience. Please refer to the "Instructions for Use" supplied with the product for specific information on indications for use, contraindications, warnings, precautions, adverse reactions and sterilization.

www.orthofix.com

GF-1102-OPT-E0 M 10/19 (0340166)

ORTHOFIX®